

ELEMENTS – Modular table system



item no.: 20007_table-frame_
STAGE_80_XS_ELEMENTS



stainless steel Aisi 1.4301
brilliant brushed surface

base frame: steel,
powder-coated
color: anthracite (100)

color example 100

Item No.: 20103

[LxWxH]: 800 x 800 x 775 mm
total weight: 21,3 kg (compact laminate)

Base

material: steel, powder-coated
profile: 40 x 40 mm
weight: 13,6 kg with height compensation
4 x castor, diameter = 65 mm
height adjustable: 855, 935, 1015 mm

Table frame (1x)

[LxWxH]: 800 x 800 x 66 mm
Item No.: 20007
material: stainless steel Aisi 1.4301
surface: brilliant brushed
weight: 7,7 kg (each)

Magnetic cable duct (2x)

[LxWxH]: 770 x 35 x 21 mm
Item No.: 11765
material: steel, powder-coated
weight: 1 kg (each)

Warranty

1 year

TOP

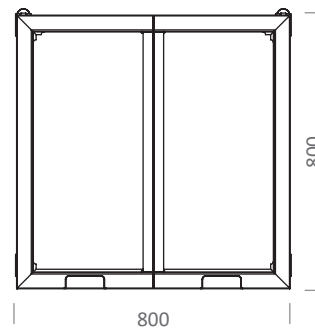

FRONT

