

Corner table to expand the buffet line.



color example 100|402

#### Item No.: 81124

[LxWxH]: 890 x 890 x 775 mm

total weight: 24,7 kg

#### Base

material: steel, powder-coated

profile: 40 x 40 mm

weight: 15 kg with height compensation

4 x castor, diameter = 65 mm

height adjustable: 840, 920, 1000 mm

#### Table-Top

material: compact laminate (9,7 kg)

#### Construction

HPL (High Pressure Laminate) compact laminate board consists of a black core layer with phenolic resin soda kraft papers and any colored top layer on both sides with decorative papers impregnated with melamine resin.

#### Classification

DIN EN 13501-1 \_B-s1, d0;

DIN EN 438-4;

DIN EN 438-7

#### Warranty

1 year

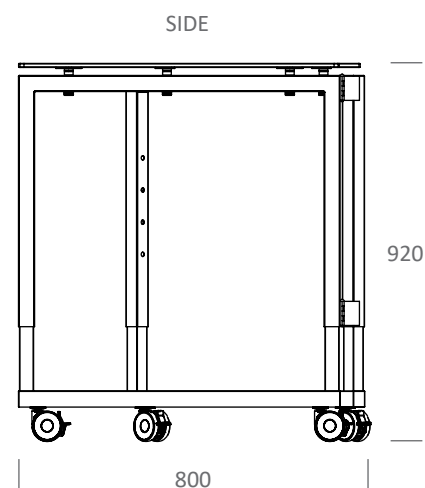
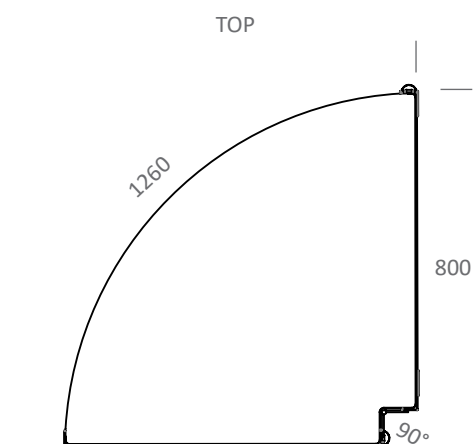

Item No.: 80125

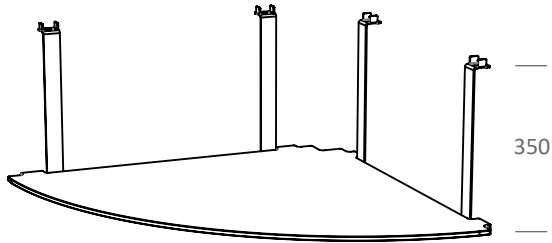

SHELF\_35\_STAGE\_80\_XS\_90\_RO  
SHELF\_47\_STAGE\_80\_XS\_90\_RO (Item No.: 80126)



Item No.: 80127



SHELF\_LOW\_STAGE\_80\_XS\_90\_RO



Flexible arrangement for your buffet

