

STAGE – the modular buffet system



color example 100|402

Item No.: 81094

[LxWxH]: 1960 x 800 x 935 mm
total weight: 159 kg (glass)
total weight: 115 kg (compact laminate)

Base

material: steel, powder-coated
profile: 40 x 40 mm
with height compensation
3 x 4 castor, diameter = 65 mm

Set of 3 tables:

- 1 x STAGE_80_L (Item No.: 81002)
- 1 x STAGE_80_M (Item No.: 81003)
- 1 x STAGE_80_S_164 (Item No.: 81056)

Height adjustable-system

- 80_L: 935, 1015, 1095, 1175 mm
- 80_M: 855, 935, 1015, 1095 mm
- 80_S_164: 775, 855, 935, 1015 mm

Table-top

- 80_L: 1950 x 790 x 10 mm (21 - 38 kg)
- 80_M: 1790 x 790 x 10 mm (19 - 35 kg)
- 80_S_164: 1630 x 790 x 10 mm (17 - 31 kg)

Warranty

1 year

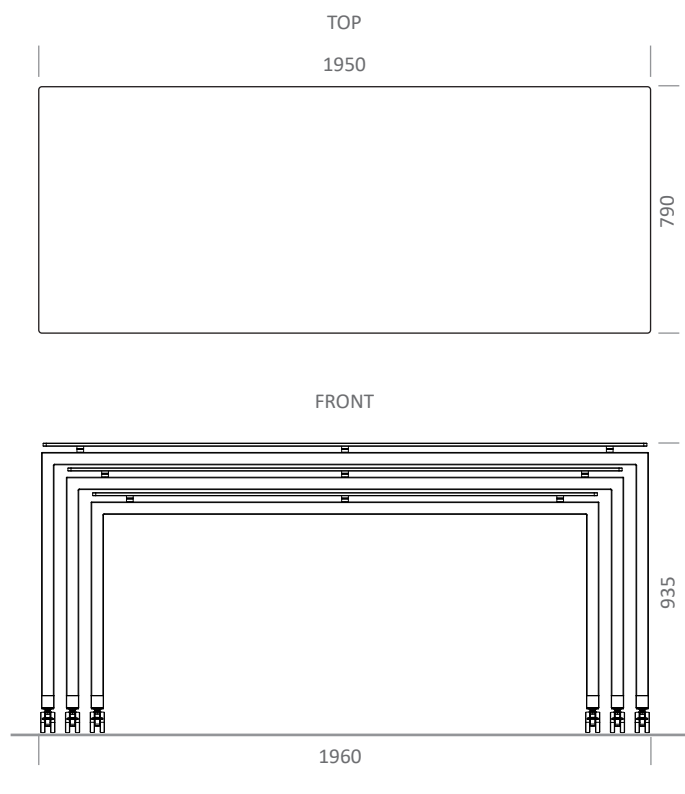

connection between table-top and base

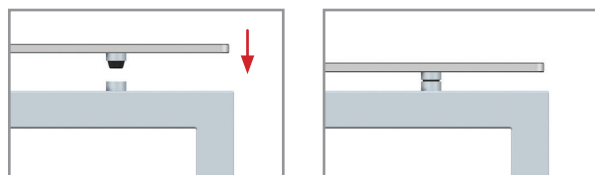

STAGE – the modular buffet system



all tables in a row and adjusted at the same height

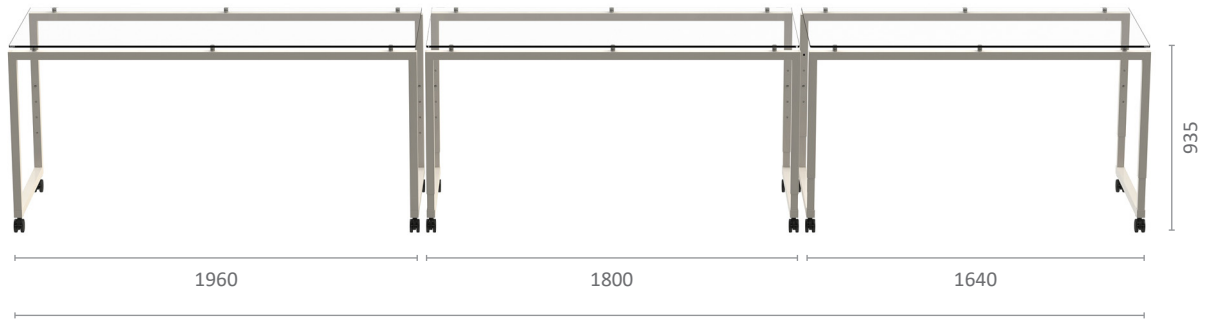

total buffet length: 5400 mm

explosion view | main parts

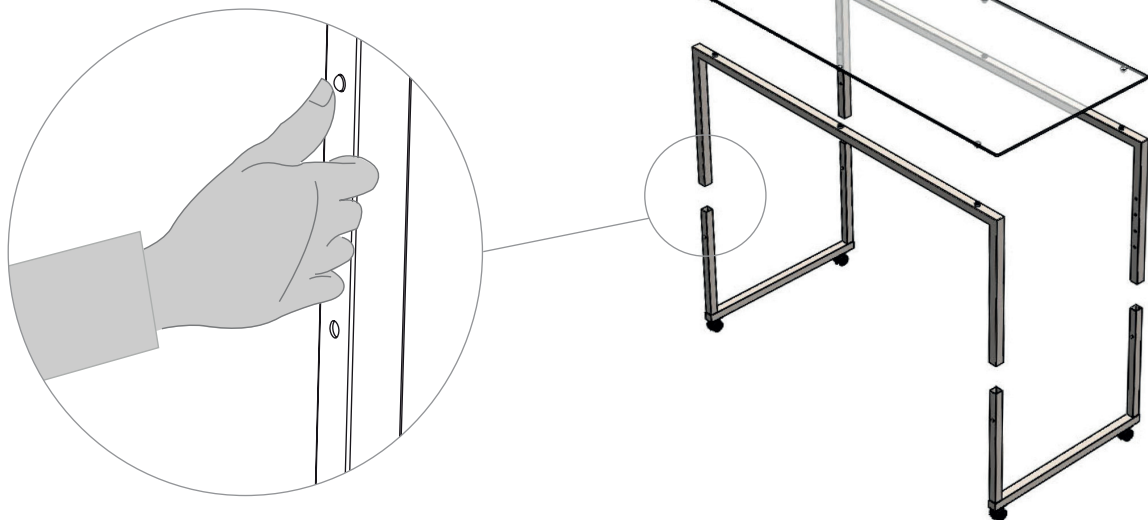

Item No.: 99106

[LxWxH]: 2038 x 870 x 670 mm

Trolley for 1 x STAGE_80 (set of 3 tables)

weight (empty): 75 kg

weight (full): 230,3 kg

