

STAGE – The modular buffet system



color example 100|402

Item No.: 20142

[LxWxH]: 1600 x 800 x 935 mm
total weight: 57,6 kg

Base

material: steel, powder-coated
profile: 40 x 40 mm
weight: 15,2 kg with height compensation
4 x castor, diameter = 65 mm
height adjustable: 1015, 1095, 1175 mm

2 x Table frame ELEMENTS

[LxWxH]: 800 x 800 x 66 mm
total weight: 2 x 7,7 kg

2 x Ice well ELEMENTS

[LxWxH]: 570 x 366 x 261 mm
total weight: 2 x 3 kg

2 x Compact top ice well ELEMENTS

[LxWxH]: 796 x 396 x 10 mm
total weight: 2 x 4,6 kg

2 x Compact top ELEMENTS

[LxWxH]: 796 x 396 x 10 mm
total weight: 2 x 4,5 kg

2 x magnetic cable duct

[LxWxH]: 770 x 35 x 21 mm
weight: 2 x 1,0 kg
material: steel, 1 mm, bended,
powder-coated anthracite (100)

Warranty

1 year

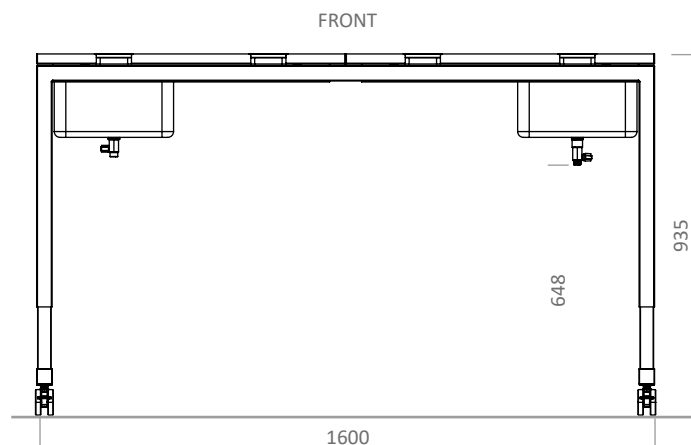
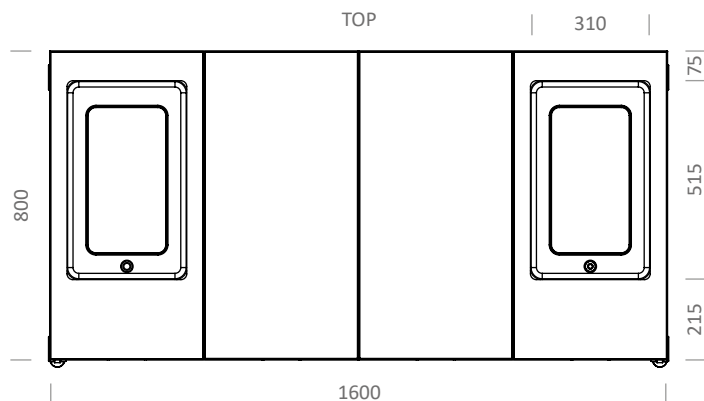

STAGE – The modular buffet system

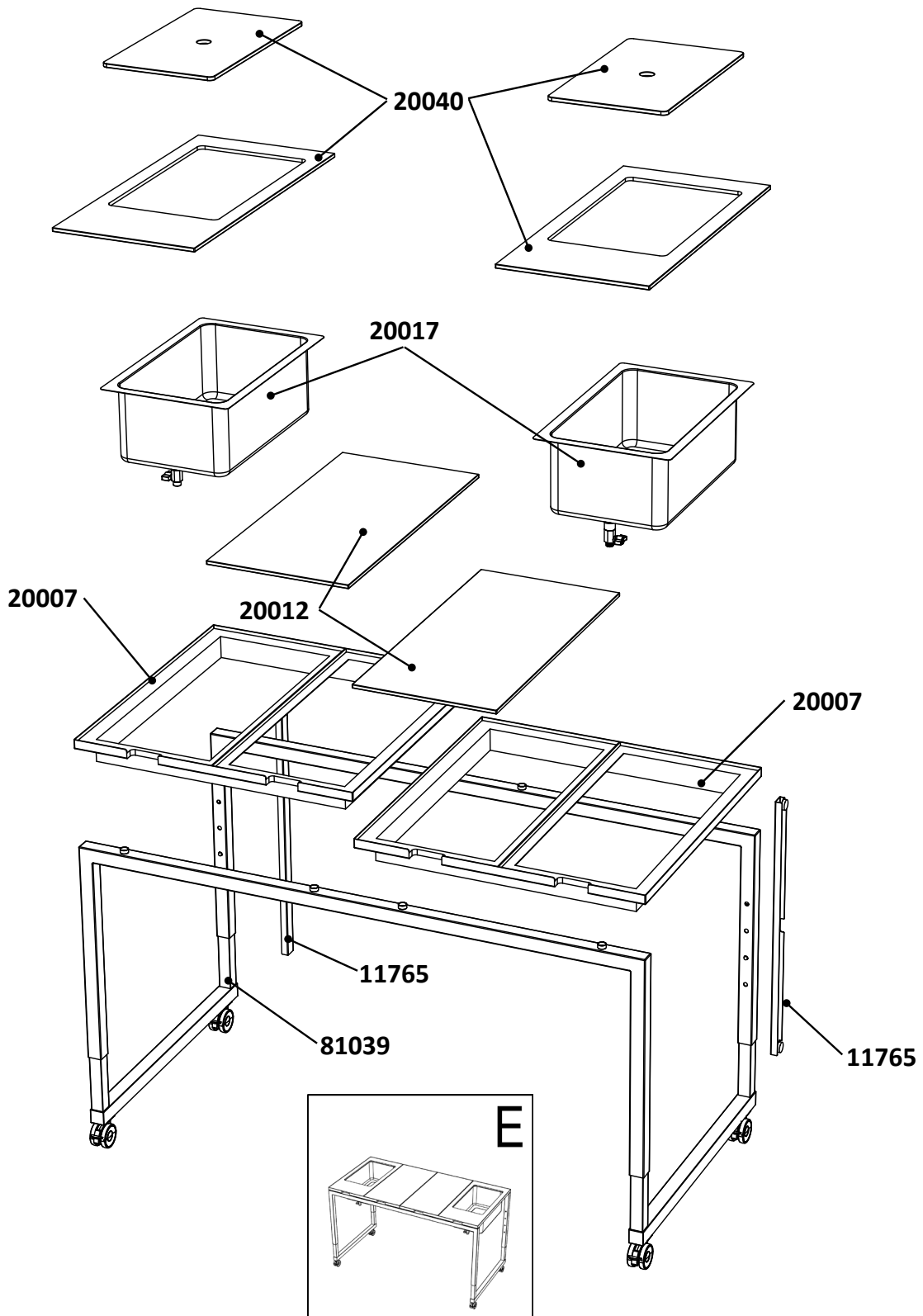

STAGE – The modular buffet system



2 x compartments can be filled with an individual selection of items
optional positions for items by rotating the frame

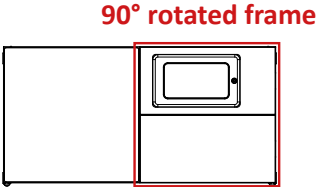
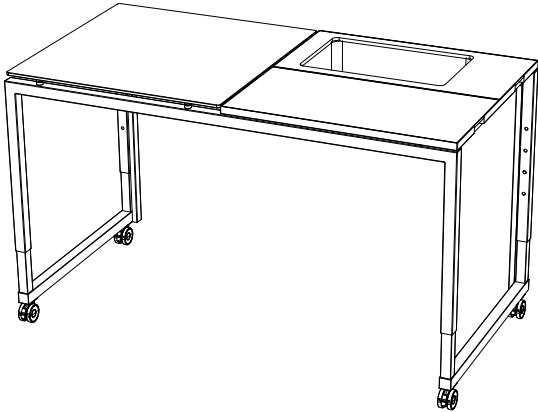
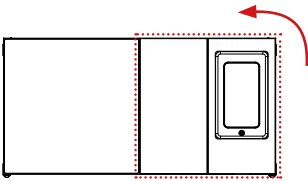
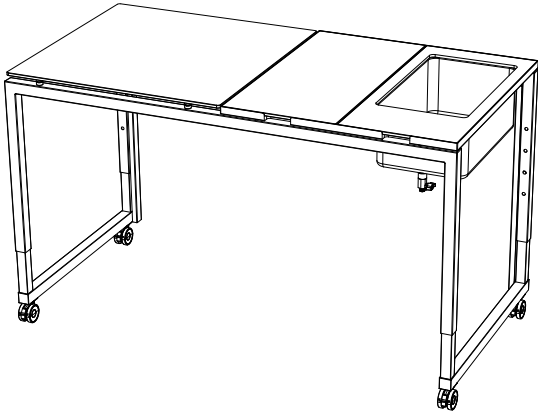

Shown in pictures above:
20142_STAGE_80_S_ELEMENTS_2_BAR_1

STAGE – The modular buffet system



selection / blinds
not included

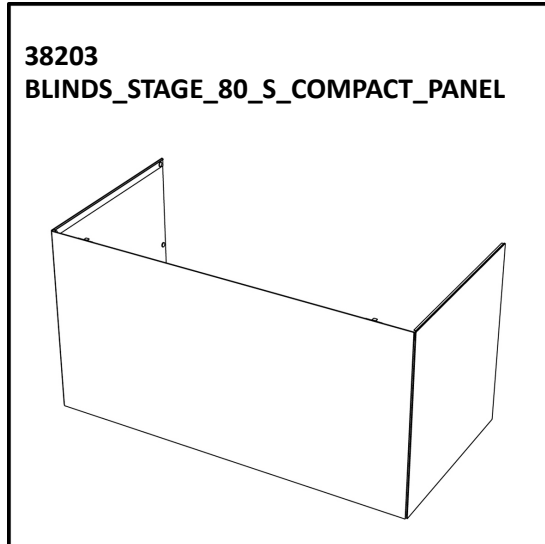

1 x 38046 FRONTBLIND_STAGE_S
2 x 38048 SIDEBLIND_STAGE_80

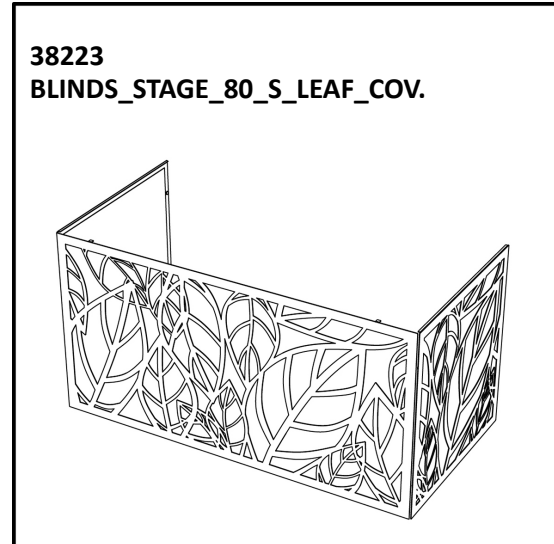

1 x 38025 FRONTBLIND_STAGE_S_LEAF_COV.
2 x 38027 SIDEBLIND_STAGE_80_LEAF_COV.

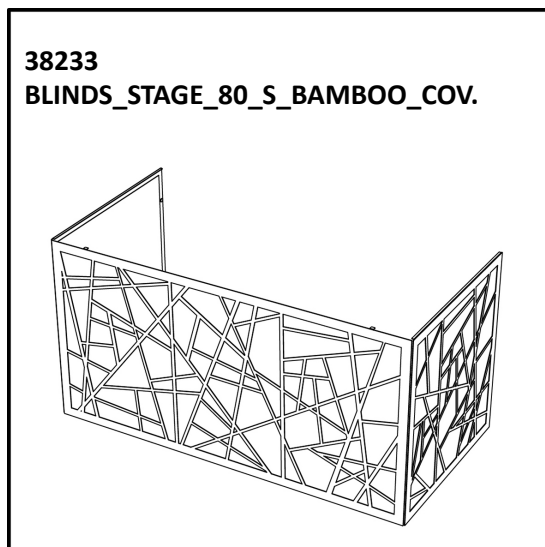

1 x 38039 FRONTBLIND_STAGE_S_BAMBOO_COV.
2 x 38041 SIDEBLIND_STAGE_80_BAMBOO_COV.

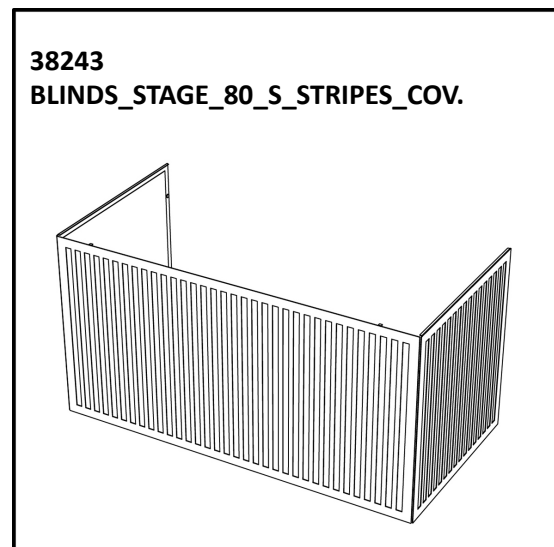

1 x 38065 FRONTBLIND_STAGE_S_STRIPES_COV.
2 x 38067 SIDEBLIND_STAGE_80_STRIPES_COV.

STAGE – The modular buffet system



selection / top box or table
not included

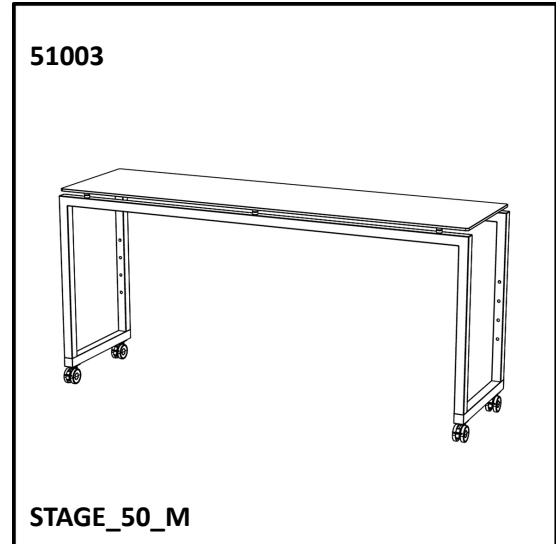
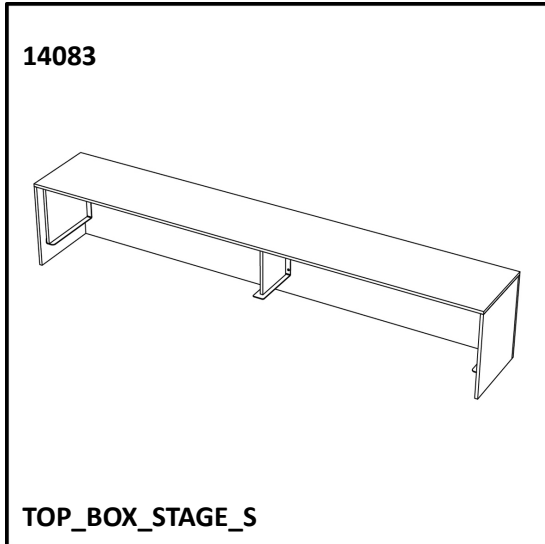

50003 / castor d=50mm
51003 / castor d=65mm (shown above)
52003 / castor d=75mm

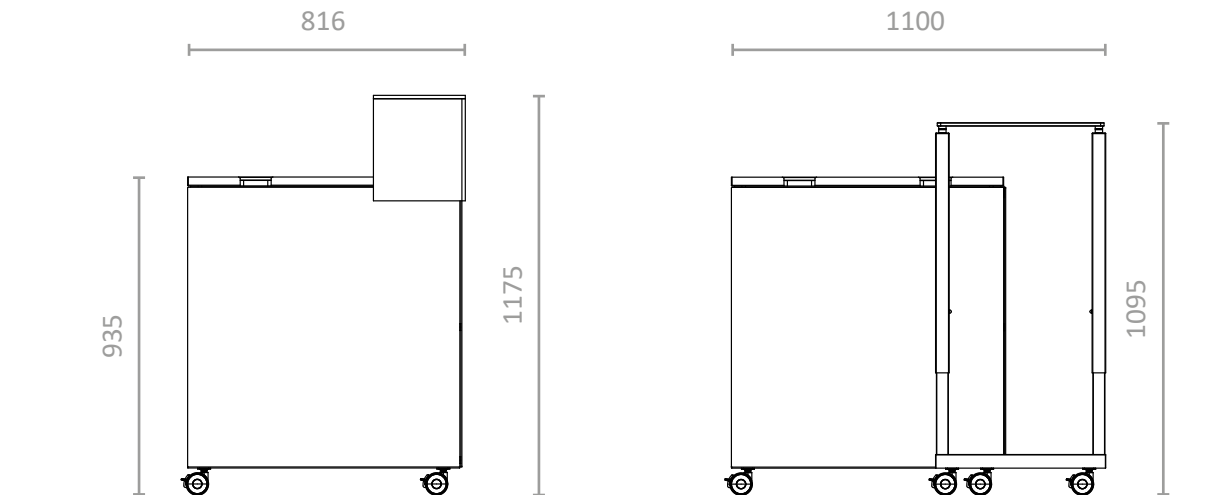

STAGE – The modular buffet system



selection / additional equipment
not included

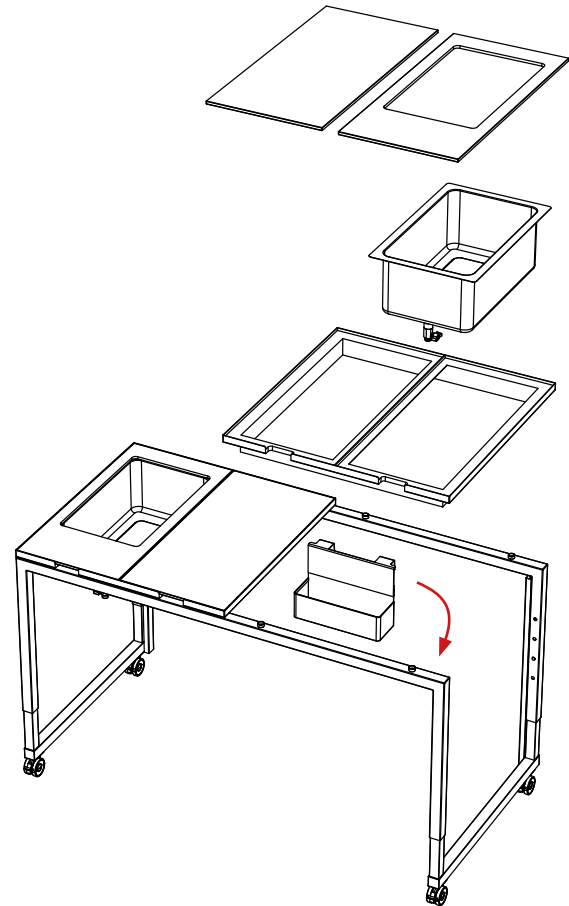
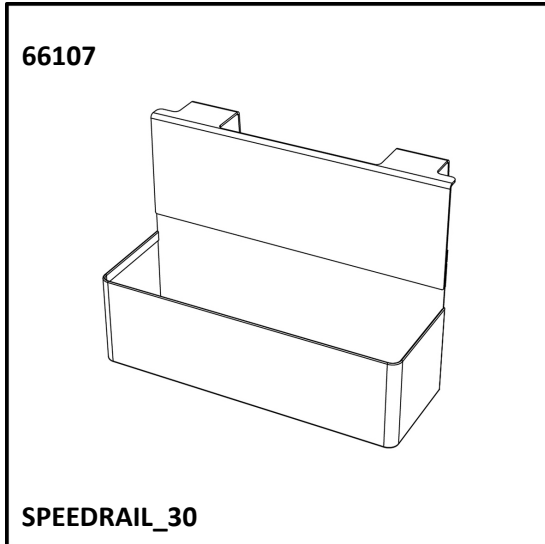

options to place the SPEEDRAIL_30

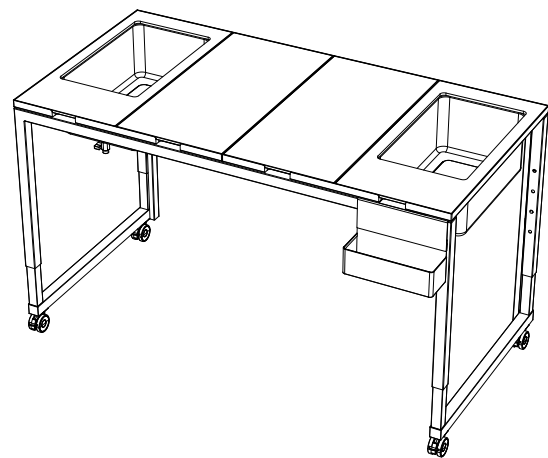
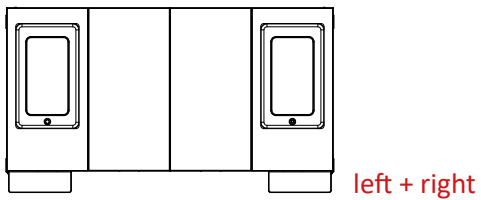
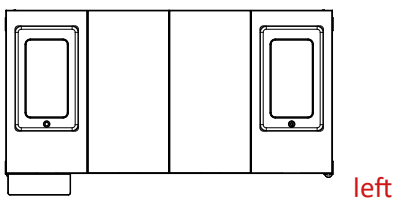
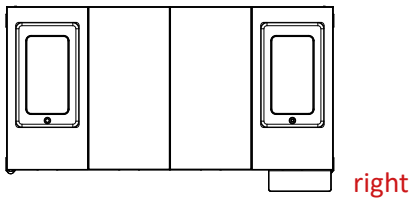

STAGE – The modular buffet system



selection / additional equipment
not included

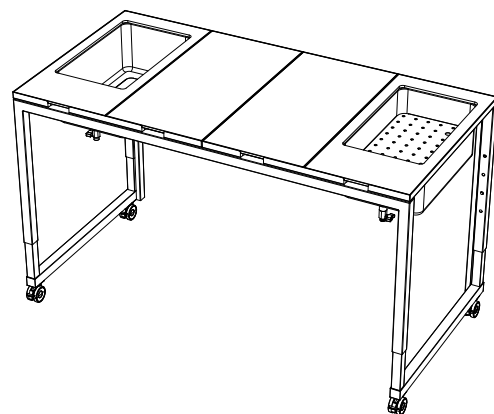
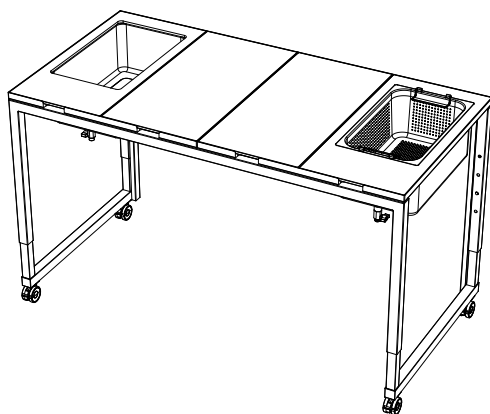
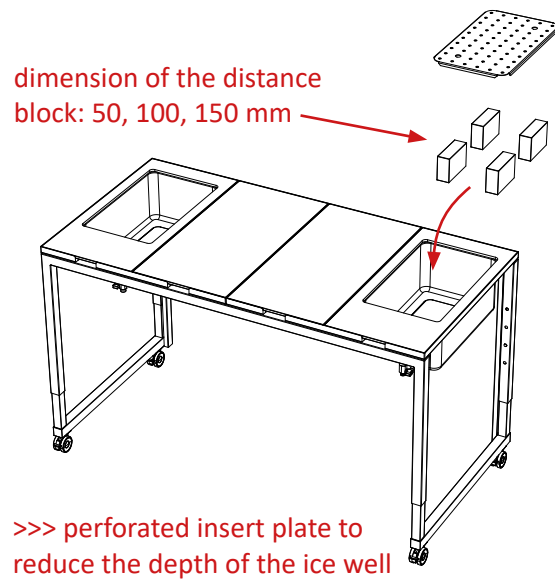
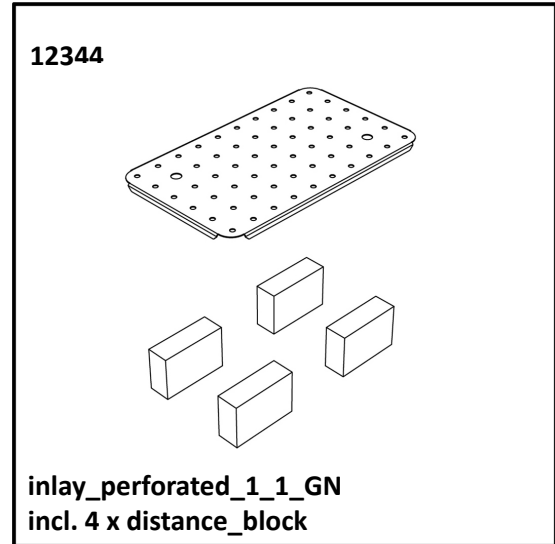

STAGE – The modular buffet system



selection / additional equipment
not included

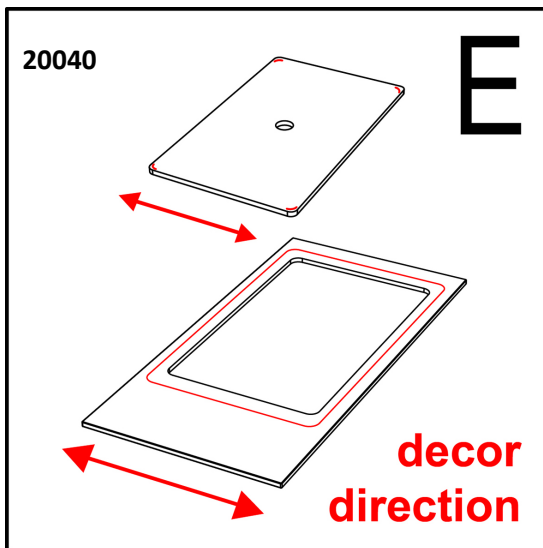
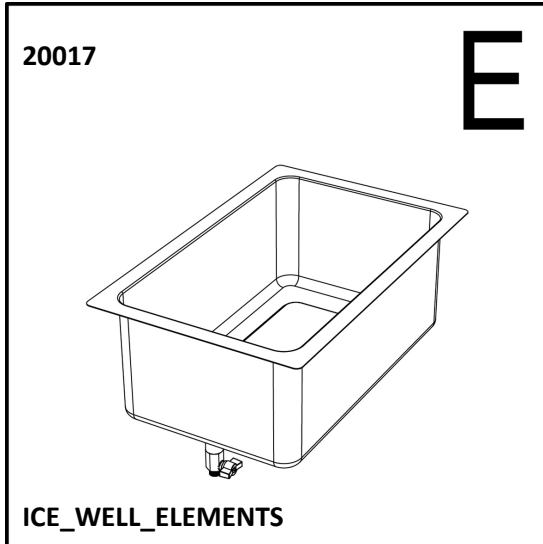

COMPACT_TABLE_TOP_ICE_WELL

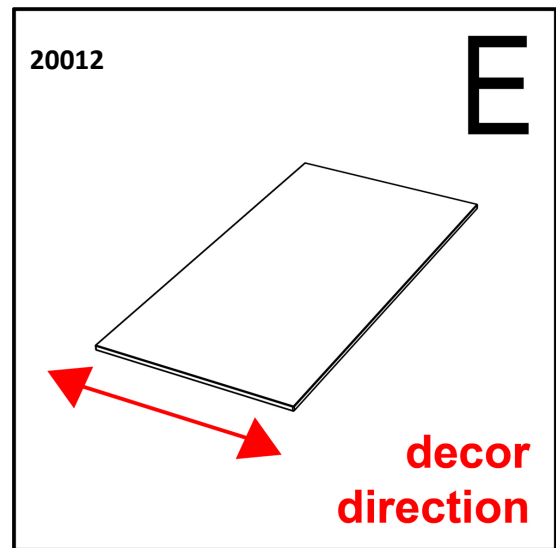

COMPACT_TABLE_TOP

STAGE – The modular buffet system



selection / additional equipment
not included

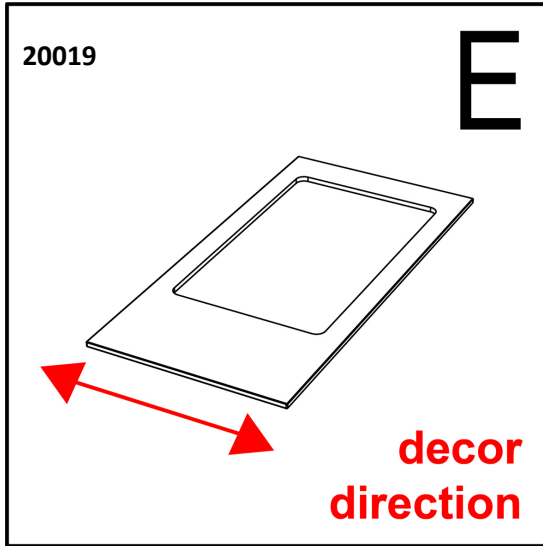

COMPACT_TABLE_TOP_1_1_GN_CUTOUT

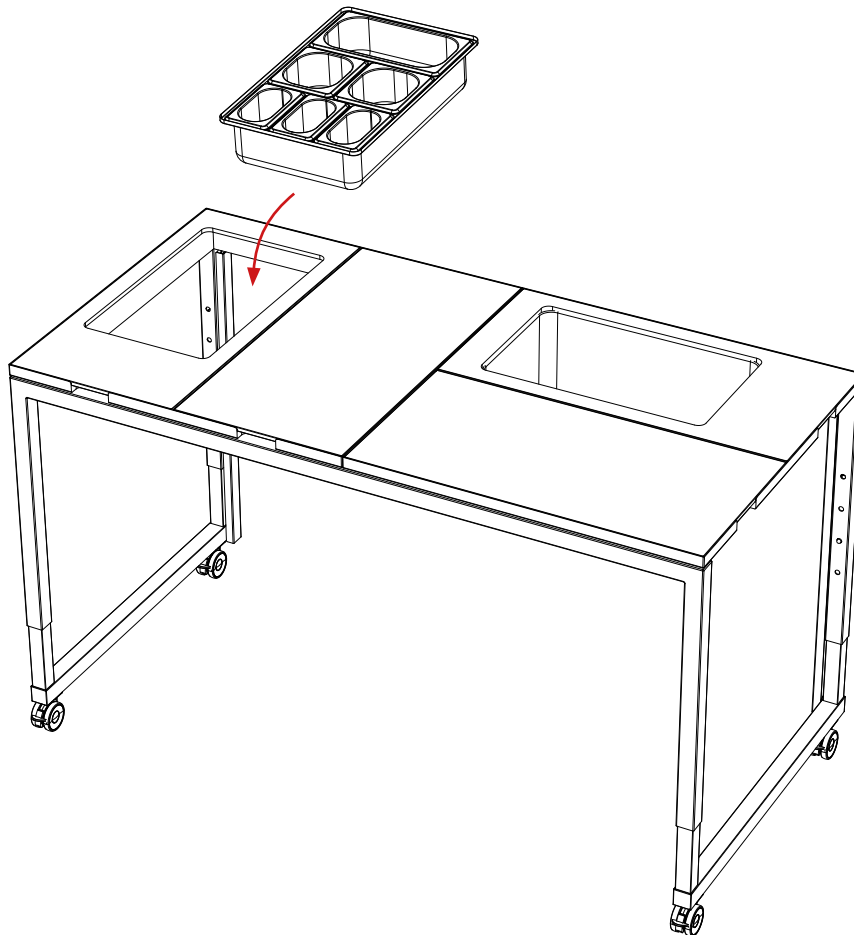
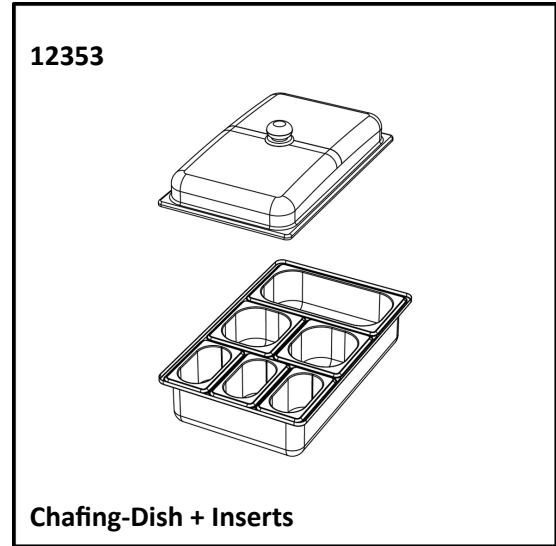

STAGE – The modular buffet system



selection / additional equipment
not included

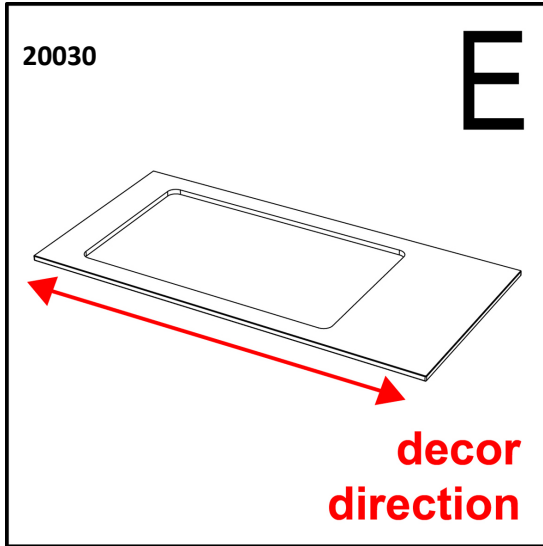

COMPACT_TABLE_TOP_1_1_GN_CUTOUT

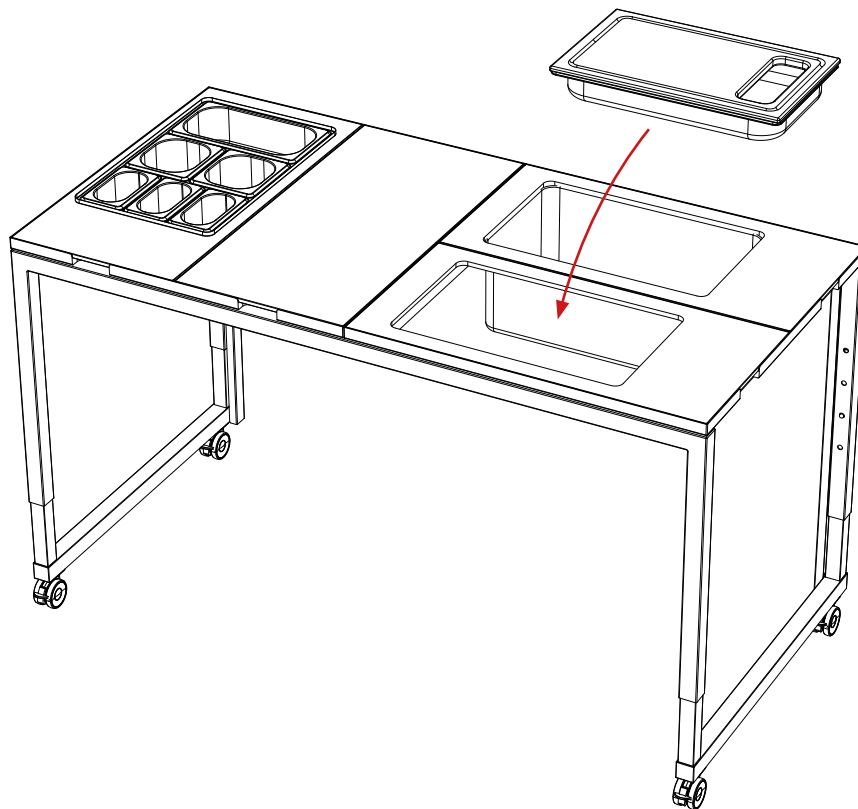
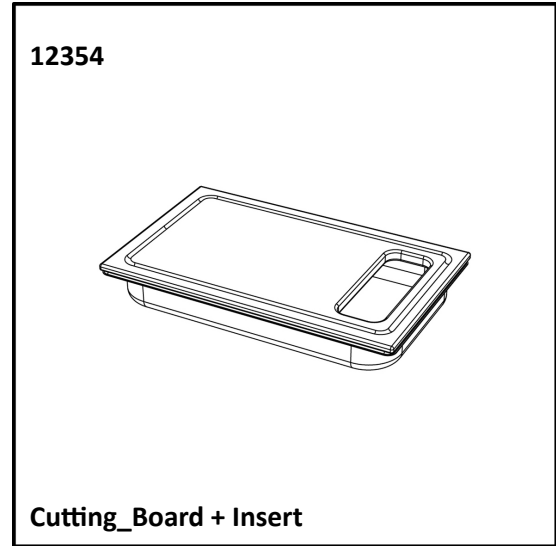

STAGE – The modular buffet system



selection / additional equipment
not included

80086 **usable height: 41 cm**

SHELF_47_STAGE_80_S

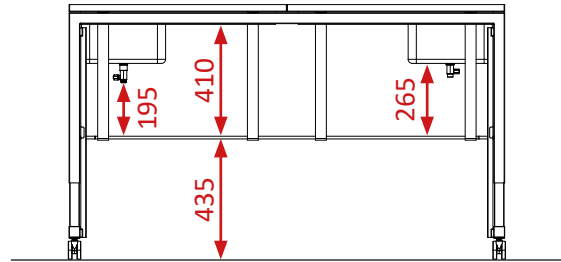

80087 **usable height: 41 cm**

SHELF_47_STAGE_80_XS

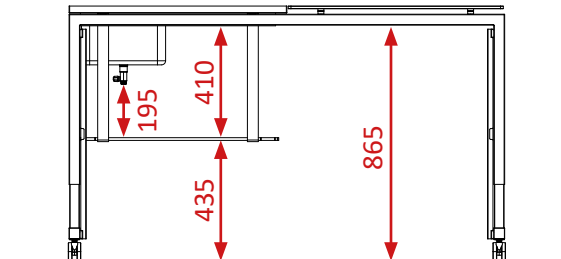

80071

SHELF_LOW_STAGE_80_S

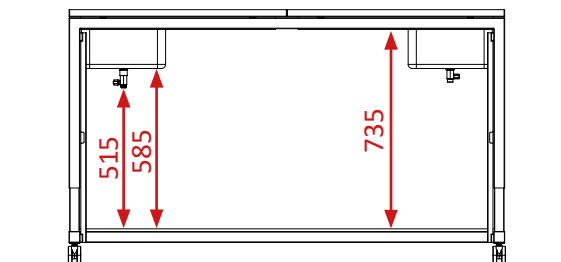

STAGE – The modular buffet system



selection / additional equipment
not included

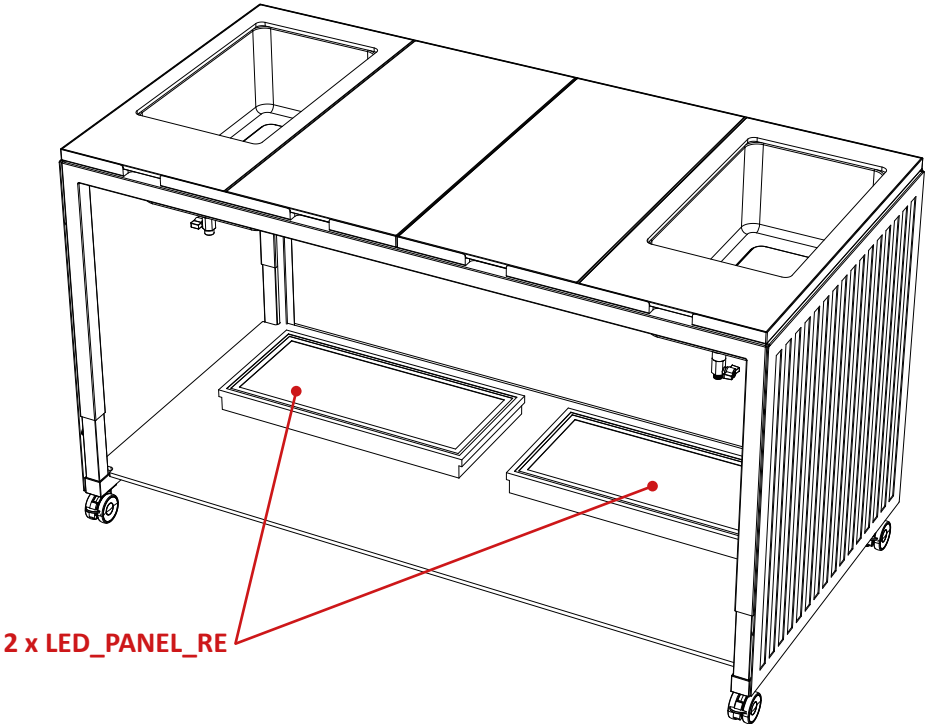

STAGE – The modular buffet system



selection / additional equipment
not included



34101

STAGE_50_BACKBAR_160_5

34001 / castor d=50mm

34101 / castor d=65mm (shown above)

34201 / castor d=75mm



34102

STAGE_50_BACKBAR_160_4

34002 / castor d=50mm

34102 / castor d=65mm (shown above)

34202 / castor d=75mm

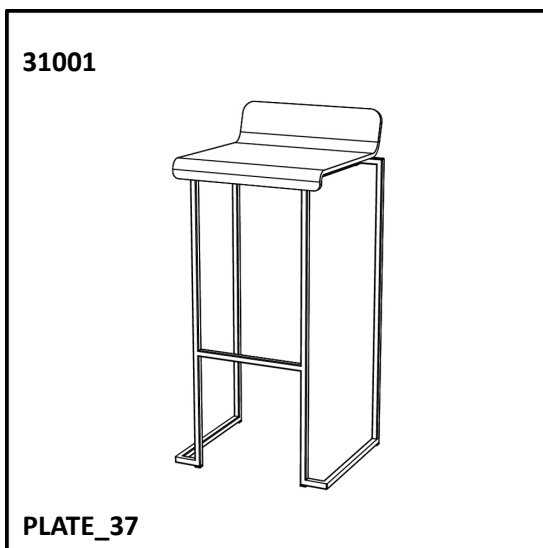

31001

PLATE_37

STAGE – The modular buffet system



selection / additional equipment
not included

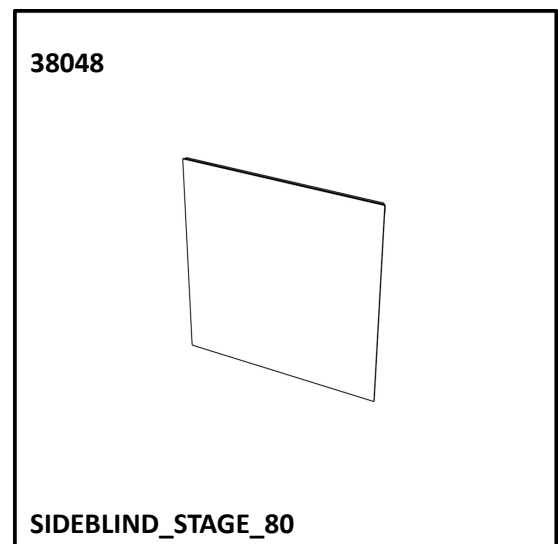
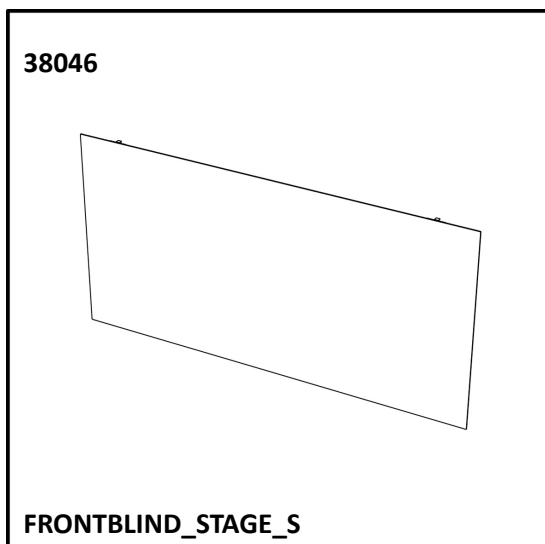
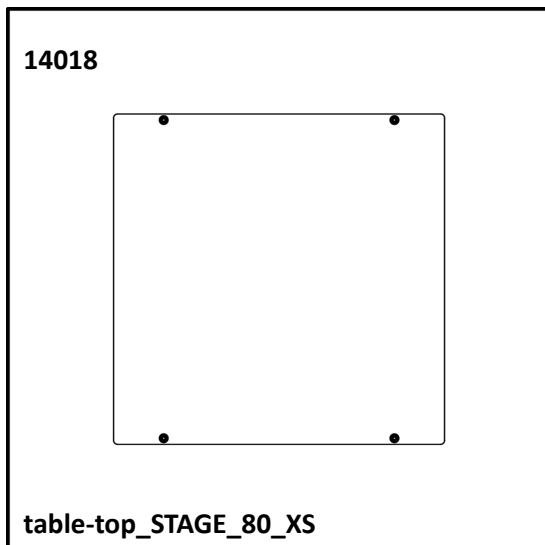
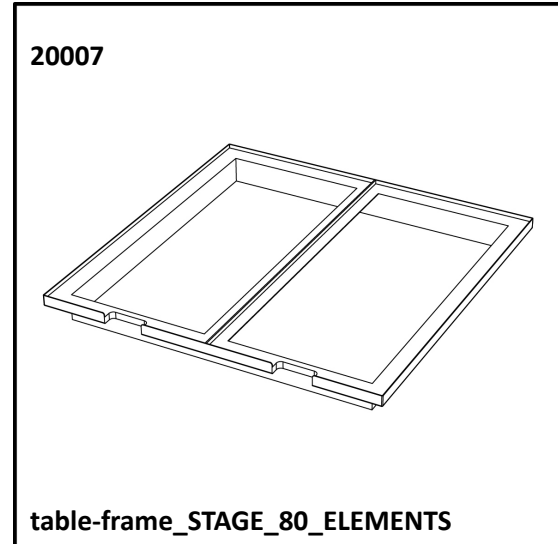
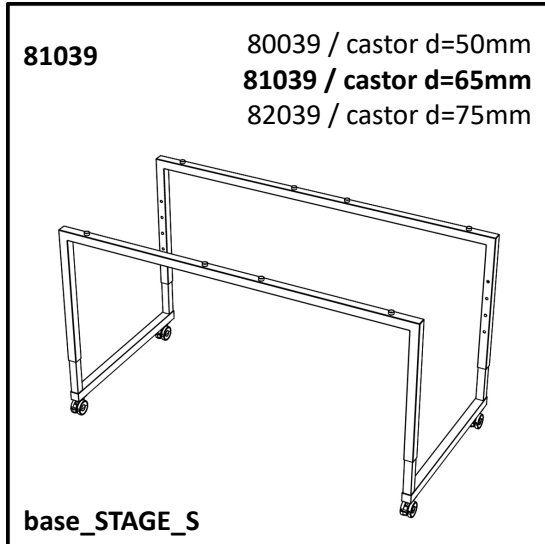

STAGE – The modular buffet system



selection / additional equipment
not included

38025

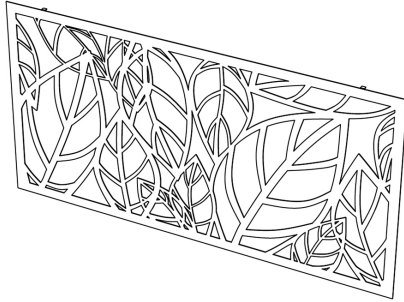

FRONTBLIND_STAGE_S_LEAF_COV.

38027



SIDEBLIND_STAGE_80_LEAF_COV.

38039

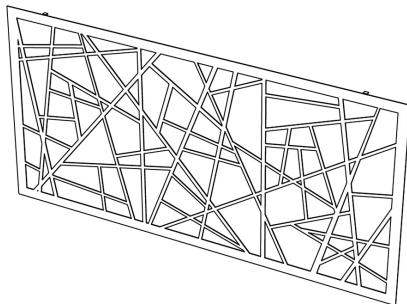

FRONTBLIND_STAGE_S_BAMBOO_COV.

38041

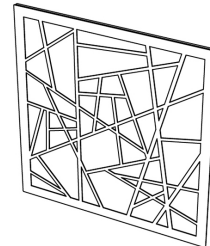

SIDEBLIND_STAGE_80_BAMBOO_COV.

38065

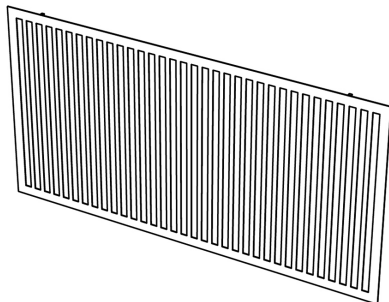

FRONTBLIND_STAGE_S_STRIPES_COV.

38067

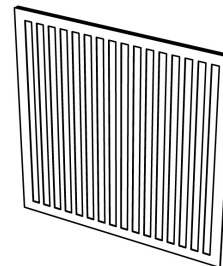

SIDEBLIND_STAGE_80_STRIPES_COV.

STAGE – The modular buffet system



selection / additional equipment
not included



11060 / magnetic_cable_holder+plugbar_5m_type_F

- 11060 / magnetic_plugbar_5m_plug_type_F
- 11061 / magnetic_plugbar_5m_plug_type_G
- 11062 / magnetic_plugbar_5m_plug_type_J
- 11063 / magnetic_plugbar_5m_plug_type_I
- 11077 / magnetic_plugbar_5m_plug_type_M

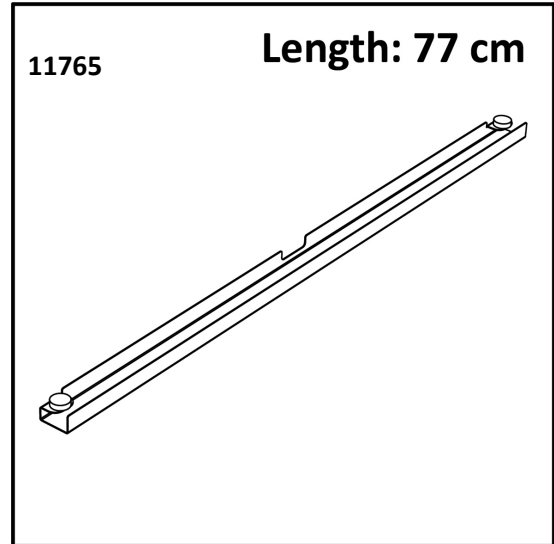

11765 / magnetic_cable_duct_770_mm

- 11765 / magnetic_cable_duct_770_mm
- 11766 / magnetic_cable_duct_610_mm
- 11767 / magnetic_cable_duct_400_mm