

STAGE – the modular buffet system



color example 100|402

Item No.: 51001

[LxWxH]: 1960 x 500 x 935 mm
total weight: 124 kg (glass)
total weight: 98 kg (compact laminate)

Base

material: steel, powder-coated
profile: 40 x 40 mm
with height compensation
4 x 4 castor, diameter = 65 mm

Set of 4 tables:

- 1 x STAGE_50_L (Item No.: 51002)
- 1 x STAGE_50_M (Item No.: 51003)
- 2 x STAGE_50_XS (Item No.: 51004)

Height adjustable-system

- 50_L: 935, 1015, 1095, 1175 mm
- 50_M: 855, 935, 1015, 1095 mm
- 50_XS: 775, 855, 935, 1015 mm

Table-top

- 50_L: 1950 x 490 x 10 mm (15 - 24 kg)
- 50_M: 1790 x 490 x 10 mm (13 - 22 kg)
- 50_XS: 790 x 490 x 10 mm (5,6 - 9,5 kg)

Warranty

1 year

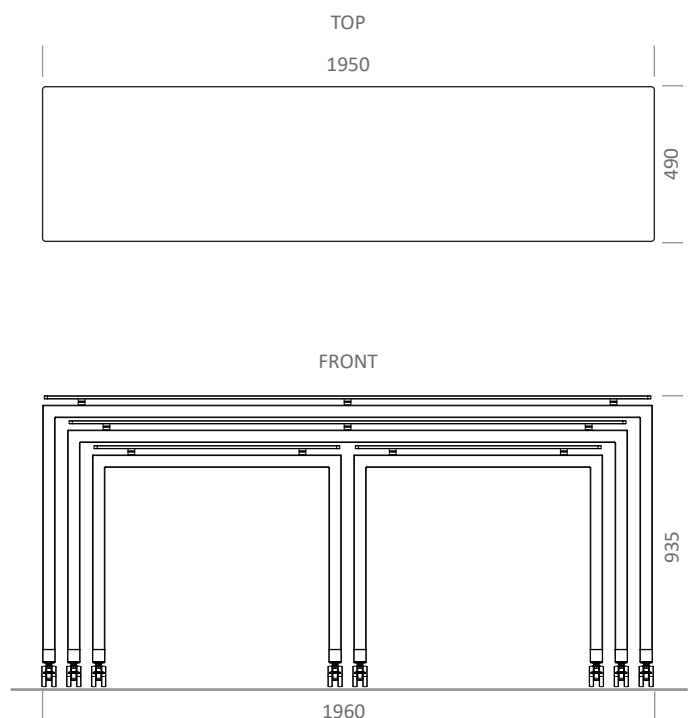

connection between table-top and base

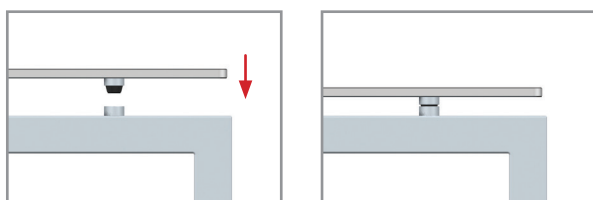

STAGE – the modular buffet system



all tables in a row and adjusted at the same height

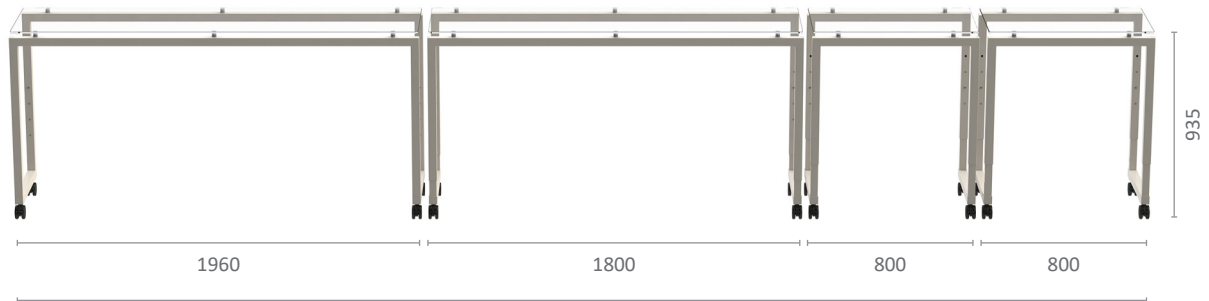

total buffet length: 5360 mm

explosion view | main parts

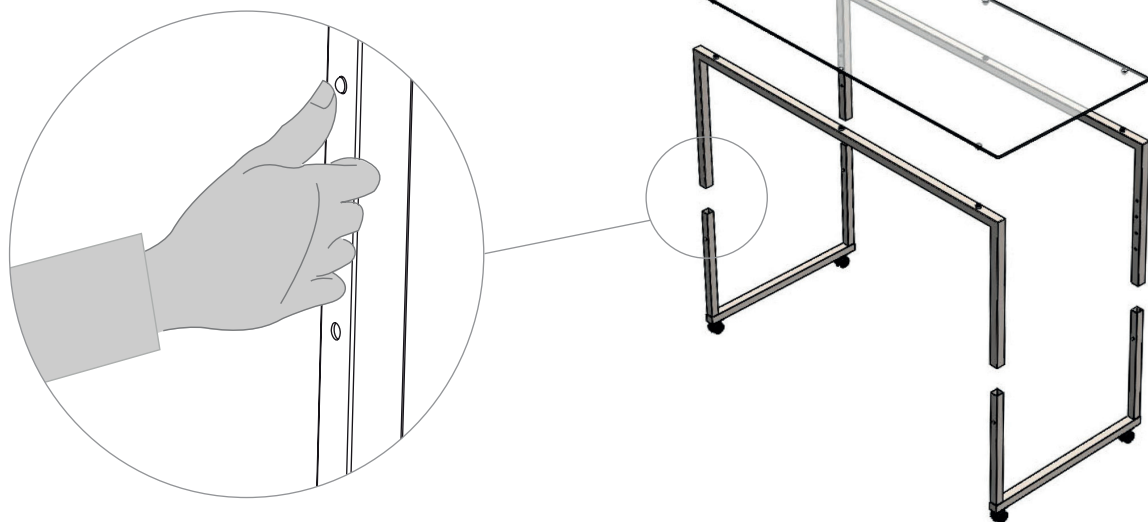

Item No.: 99106

[LxWxH]: 2038 x 870 x 670 mm

Trolley for 1 x STAGE_50 (set of 4 tables)

weight (empty): 75 kg

weight (full): 173 kg

