

STAGE – the modular buffet system



color example 100|402

**Item No.: 51050**

[LxWxH]: 1960 x 500 x 935 mm  
total weight: 115,5 kg (glass)  
total weight: 87 kg (compact laminate)

**Base**

material: steel, powder-coated  
profile: 40 x 40 mm  
with height compensation  
4 x 4 castor, diameter = 65 mm

**Set of 3 tables:**

- 1 x STAGE\_50\_L (Item No.: 51002)
- 1 x STAGE\_50\_M (Item No.: 51003)
- 1 x STAGE\_50\_S\_164 (Item No.: 51017)

**Height adjustable-system**

- 50\_L: 935, 1015, 1095, 1175 mm
- 50\_M: 855, 935, 1015, 1095 mm
- 50\_S\_164: 775, 855, 935, 1015 mm

**Table-top**

- 50\_L: 1950 x 490 x 10 mm (15 - 24 kg)
- 50\_M: 1790 x 490 x 10 mm (13 - 22 kg)
- 50\_S\_164: 1630 x 490 x 10 mm (12 - 20 kg)

**Warranty**

1 year

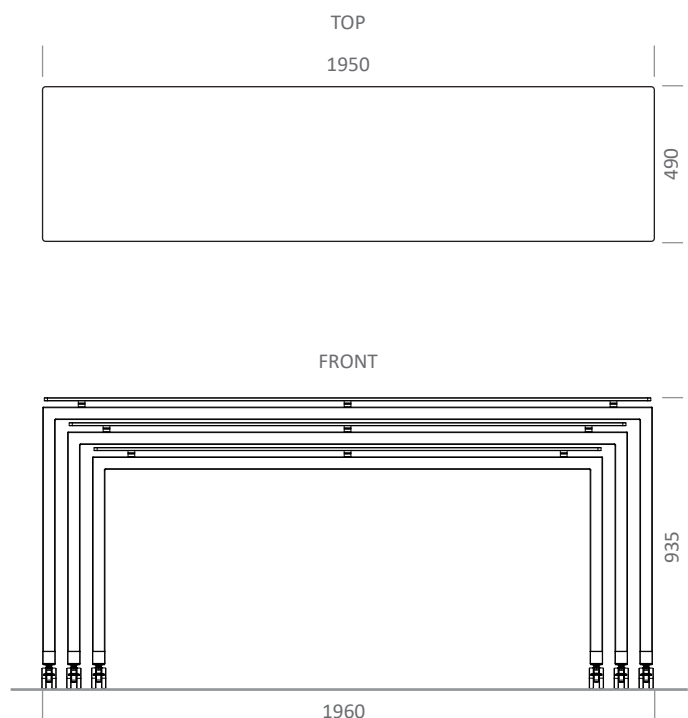

**connection between table-top and base**

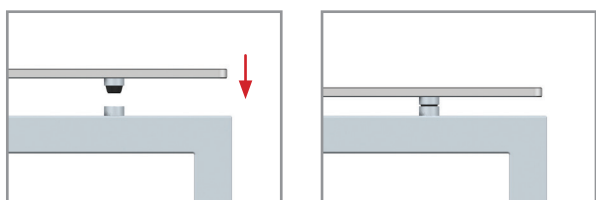

**STAGE – the modular buffet system**



all tables in a row and adjusted at the same height

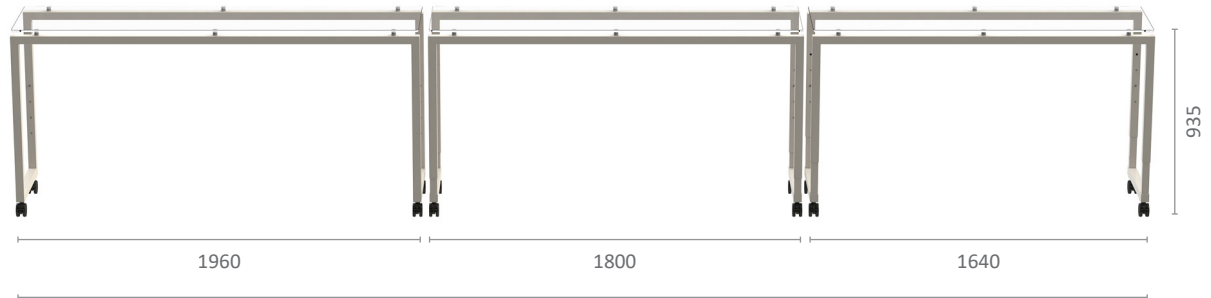

total buffet length: 5400 mm

explosion view | main parts

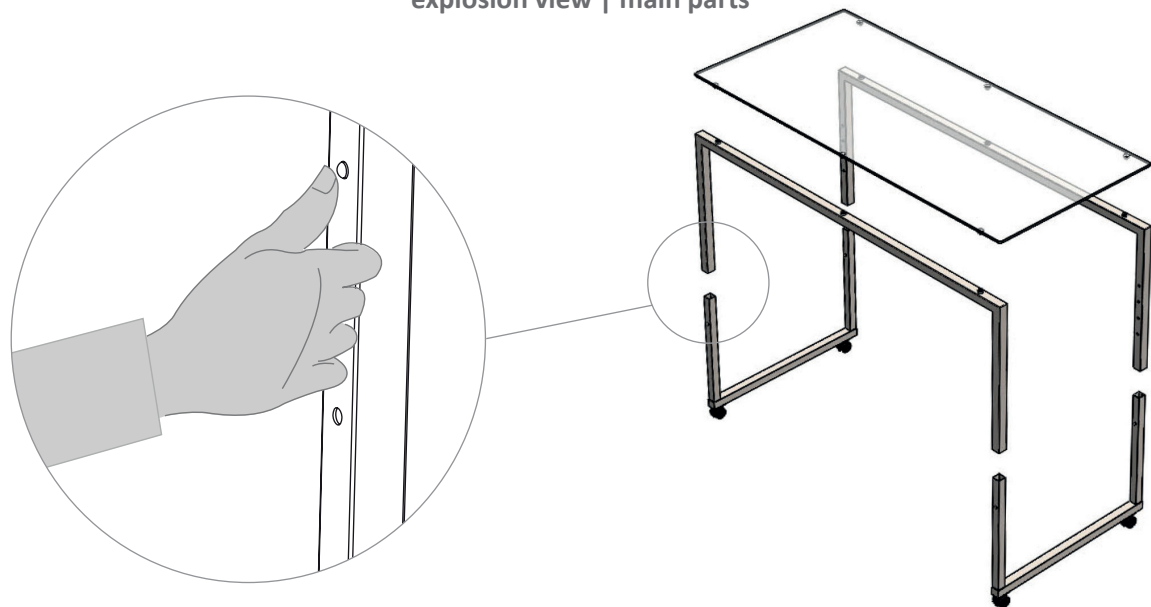

**Item No.: 99106**

[LxWxH]: 2038 x 870 x 670 mm

Trolley for 1 x STAGE\_50 (set of 3 tables)

dimensions: 2050 x 870 mm

weight (empty): 75 kg

weight (full): 162 kg

